

# FV1 FOOT CHECK VALVE PVC-U

## FEATURES

The FV1 foot check valve with strainer is an ogive valve intended for current valve applications. This PN10 valve makes it possible to prevent draining water or an acid\* or a alkaline fluid\* from transfer pumps during a shut-down. Due to its ogive shape, the valve can be mounted horizontally or vertically. The materials used are anti-UV coated. Fully removable model. Possible addition of a stainless steel spring to increase the opening pressure.

\*Cf. Sectoriel's table of resistance of materials

## AVAILABLE VERSIONS

Body gasket: PVC-U

Gaskets: EPDM or FPM

Diameter: DN15 to DN50

Connection: female end according to DIN/ISO

## LIMITS OF USE

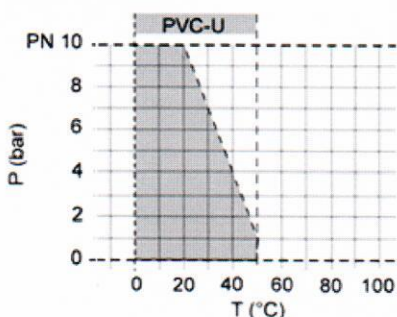

The limits of each material are valid for the nominal pressures indicated, and for a service life of 25 years. These are indicative values for non-hazardous transported materials (DIN 2403), for which the valve material is resistant. Please contact us for use at temperatures below 0°C.



## DIMENSIONS (mm)

DN	d	d1	d2	D	L	L1
15	20	20.30	20.10	54	109	22.3
20	25	25.30	25.10	63	137.5	25.5
25	32	32.30	32.10	73.5	153	28.6
32	40	40.30	40.10	84.5	181.5	32
40	50	50.30	50.10	98	204	35
50	63	63.30	63.10	119	239	38

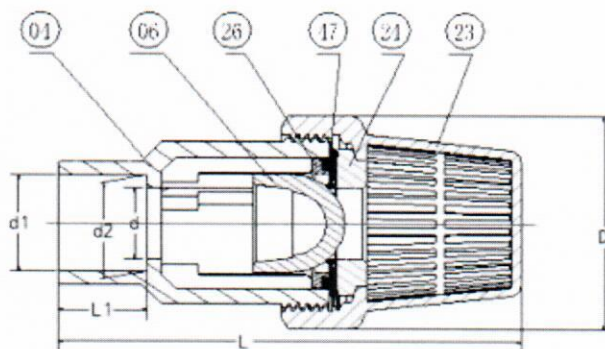

15 - 50

## CONSTRUCTION

N°	Item	SL1 PVC-U
01	Body	PVC-u
06	Ogive	PVC-u
23	Strainer	PVC-u
24	Collar	PVC-u
26	Support ring	PVC-u
47	Body gaskets	EPDM / FPM